

**HORIZONTAL WINDLASS
3500 SERIES**

VETUS-MAXWELL APAC Ltd

© Copyright Vetus-Maxwell APAC Ltd. All rights reserved.

Vetus-Maxwell APAC Ltd reserves the right to make engineering refinements on all products without notice. Always consult manual supplied with product as details may have been revised.

Illustrations and specifications are not binding as to detail.

Contents

1.0	INTRODUCTION	2
1.1	PRE-INSTALLATION NOTES	2
1.2	PRODUCT VARIATIONS	3
1.3	SPECIFICATIONS	4
2.0	INSTALLATION	5
2.1	SELECTION OF POSITION FOR THE WINDLASS	5
2.2	PREPARATION OF MOUNTING AREA	6
2.3	PREPARATION OF THE WINDLASS	6
2.4	INSTALLING THE WINDLASS	7
2.5	POWER CONNECTIONS TO DC MOTOR	7
2.6	POWER CONNECTIONS TO HYDRAULIC MOTOR	8
2.7	INSTALLATION OF CONTROLS	9
3.0	USING THE WINDLASS	10
3.1	PERSONAL SAFETY WARNINGS	10
3.2	LOWERING THE ANCHOR UNDER POWER	11
3.3	RETRIEVING THE ANCHOR UNDER POWER	11
3.4	LOWERING THE ANCHOR UNDER MANUAL CONTROL	11
3.5	RETRIEVING THE ANCHOR UNDER MANUAL CONTROL	12
3.6	OPERATING THE WARPING DRUM INDEPENDENTLY	12
4.0	MAINTENANCE	13
4.5	RECOMMENDED LUBRICANTS	14
5.0	DISASSEMBLING THE WINDLASS	15
5.1	REMOVAL OF PARTS EXTERNAL OF CASE	15
5.2	REMOVAL OF PARTS INTERNAL OF CASE	15
5.3	ASSEMBLY OF PARTS	16
5.4	SPARE PARTS	17
5.5	TOOLS FOR MAINTENANCE	17
6.0	TROUBLESHOOTING	18
	APPENDIX A - Dimensional drawings	19
	APPENDIX B - Spare Parts	23
	APPENDIX C - Electric Wiring schematics	28
	APPENDIX D - Warranty Form	34

1.0 INTRODUCTION

1.1 PRE-INSTALLATION NOTES

- Read this manual thoroughly before installation and using the windlass. Failure to adhere to the correct procedures, recommendations and guidelines described in this Owner's Manual may invalidate the warranty.
- Be mindful that the correct selection of windlass for each application, together with correct installation, normal care in use and maintenance, are essential for long life and reliable performance.
- Inspect your windlass carefully when unpacked. Any damage or lack of components should be reported immediately to your Maxwell distributor.
- The windlass is supplied with chainwheel, as specified on purchase order. Make sure it is the appropriate one for the chain being used on board. Correct fit of the chain to chainwheel is essential for reliable and safe operation of the windlass. This can be guaranteed only when calibrated chain to a recognised international standard is used and the chain is correctly identified to Maxwell, or if a chain sample is provided to Maxwell to develop a custom chainwheel.
- The windlass is designed for use in conjunction with chain stopper of the appropriate size. Their use is an important safety feature.
- For side pocket anchors, a chain roller should be installed above the hawse pipe to ensure smooth and quiet travel of the chain from deck to hawse pipe. The roller requires a central groove to align chain and flat faces (for longer chains) to support and avoid bending the chain links.
- The connection of the power lines and control circuitry to the windlass must be done by skilled technicians, to ensure reliable and safe operation of the windlass.

1.2 PRODUCT VARIATIONS

There are several options of chainwheel and drum arrangements, combined with three types of drives.

The types of topworks are:

- Double Drum / Double Chainwheel – Picture 1.1
- Port Drum / Starboard Chainwheel – Picture 1.2
- Double Chainwheel – Picture 1.3
- Double Drum / Starboard Chainwheel – Picture 1.4
- Port Drum / Double Chainwheel – Picture 1.5

The types of drives are:

- Electric DC drive (24V or 12V)
- Hydraulic drive

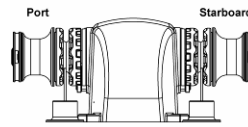

Picture 1.1

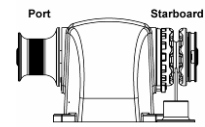

Picture 1.2

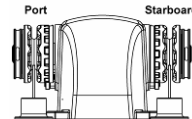

Picture 1.3

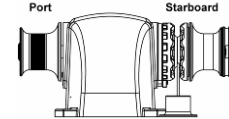

Picture 1.4

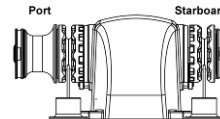

Picture 1.5

Chainwheels

The chainwheel numbers consist of two parts: main part number and suffix, for example 3182-001.

The main part number refers to the type of chainwheel and the suffix refers to size and type of chain.

Please refer to your closest Maxwell Marine agent or distributor (Appendix D), who will select the correct replacement chainwheel for your chain.

1.3 SPECIFICATIONS

Electric DC Drive 12V	
Line speed at normal working load.	15m/min (50ft/min)
Maximum pull capacity.	1590kg (3500lb)
Current at normal working load.	110-160A
Current at stall.	450A
Motor power	1.2kW (1.6HP)
Weight – Single drum / Single chainwheel	56.7kg (124.7lb)
Weight – Double drum / Double chainwheel	72.6kg (159.7lb)
Weight – Vertical drum / Double chainwheel	94.5kg (207.9lb)

Electric DC Drive 24V	
Line speed at normal working load.	15m/min (50ft/min)
Maximum pull capacity	1590kg (3500lb)
Current at normal working load.	66-88A
Current at stall.	240A
Motor power	1.2kW (1.6HP)
Weight – Single drum / Single chainwheel	56.7kg (124.7lb)
Weight – Double drum / Double chainwheel	72.6kg (159.7lb)
Weight – Vertical drum / Double chainwheel	94.5kg (207.9lb)

Hydraulic Drive	
Line speed at normal working load.	15m/min (50ft/min)
Recommended hydraulic oil flow	40l/min (11USgal/min)
Maximum hydraulic oil flow	48l/min (13USgal/min)
Continuous pull capacity	1590kg (3500lb)
Maximum hydraulic oil pressure	138bar (2000psi)
Motor port size (pressure and return)	7/8"-14UNF
Weight – Single drum / Single chainwheel	48.5kg (106.7lb)
Weight – Double drum / Double chainwheel	64.4kg (141.7lb)
Weight – Vertical drum / Double chainwheel	79.9kg (175.8lb)

! Rated capacity and chain speed is based on the chainwheel for 10mm chain. The performance may vary by up to ±10% when other size chainwheels are used.

Hydraulic oil characteristics

Viscosity: ISO 32 - 68 (at 20°C)

Suitable oils:	Shell Rimula X 15W-40;	Shell Myrina M 15W-40
	Penzoil SAE 10W-40	Texaco 2109 SAE 15W
	Texaco 1814 SAE 10W-40	BP HLPHM 32-68
	BP Autrans T0410	

2.0 INSTALLATION

2.1 SELECTION OF POSITION FOR THE WINDLASS

Position of the windlass should be selected together with positions of the hawse pipe.

Allow the chain a straight run from the bow roller to the chainwheel with no more than a 2° deviation from horizontal (Picture 2.1).

The bow roller should have a vertical groove to suit the profile of the chain. This will align the chain so that it enters the chainwheel without twisting.

The fitting of a chain stopper is essential to take the load off the windlass while the vessel is at anchor. It must be correctly aligned with the direction of chain and installed at appropriate height to avoid the chain rubbing over chain stopper body or pawl. Make sure the chain stopper clears the anchor shank.

A tensioner device to tension the anchor into its pocket is recommended. If the anchor is not snug in the pocket, it could cause damage to the pocket in a heavy seaway.

Ensure a minimum of 600mm (23") clearance between the underside of deck and the chain piled up in the chain locker (Picture 2.2). This will assist kinks, which may develop in outgoing chain, to shake free.

The chain must gravity feed into the locker. If the chainpipe cannot be positioned directly over the locker, a heavy wall pipe can be used to direct the chain to the required area. It is important that the chain slips through the pipe easily; completely unaided, sharp corners should be avoided. It may be necessary to provide the pipe with a bell mouth or to bell mouth the entrance to the chainpipe from the locker to assist the free flow of the chain from the locker.

The chain locker must be of such a size and shape that the chain will heap up and feed out naturally without fouling.

To ensure safe position of the operator while tailing from the warping drum, footswitches should be positioned at least 700mm (28") away from the windlass.

The below deck portion of the footswitch should not be exposed to water or wet environment and the breather holes must be kept clear. The arrows on the footswitches should be arranged to indicate the direction of operation.

The motor starter (solenoid valves for hydraulic windlasses) should be located in a dry area in close proximity to the windlass. It must not be located in the wet environment of the chain locker.

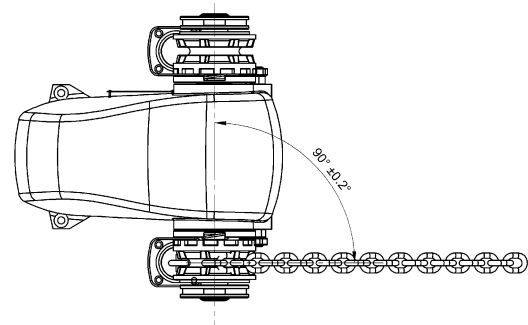

Picture 2.1
Correct angle of chain

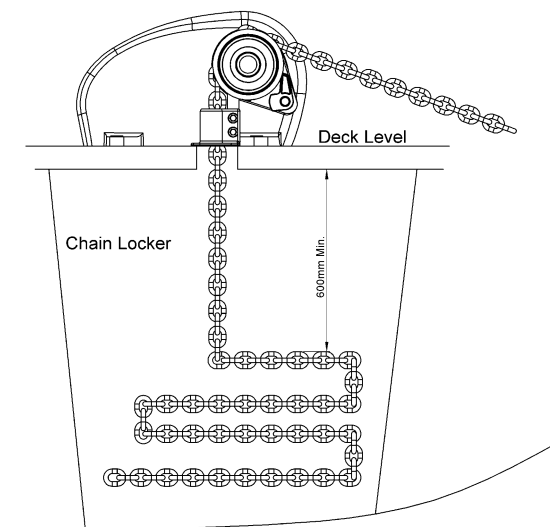

Picture 2.2
Recommended free space in chain locker

2.2 PREPARATION OF MOUNTING AREA

It is of paramount importance that the vessel has sufficient deck reinforcing and total structural strength to sustain the loads that can be transmitted to the mounting area of the windlass and chain stopper. This should be equal to the loading of the equipment to beyond breaking strength of the chain.

The mounting area for the windlass must be perfectly flat and rigid. Structural grade fillers can be used to level this area if initial flatness is inadequate. Mounting area for the chain stopper should be prepared at the same time. The chain stopper has to be installed at an appropriate angle to ensure that chain goes straight when it comes out of the chain stopper and into windlass.

If hawse pipe is angled outboard from deck to anchor pocket, the chain stopper should also be angled by half of the angle of the hawse pipe (Picture 2.3). That will help to reduce twisting of the chain between the chain stopper and the windlass and ensure good fit of the chain into the chainwheel. The chain stopper can be installed vertically if the hawse pipe angle is less than 4°.

A deck cutout detail drawing is enclosed with these instructions to assist in marking out all the drilling and cutting required for installing the windlass. Before drilling and cutting, check the marked out area is dimensionally correct and make any necessary corrections.

2.3 PREPARATION OF THE WINDLASS

The Windlass should be bolted to the deck using four 12mm (½") 316 Stainless Steel bolts of suitable length to accommodate the deck thickness.

The nuts under the deck should be strengthened with larger diameter thick stainless steel washers or a stainless steel clamp plate bridging between each of the forward bolts and rear bolts to spread the load.

If the deck is steel or aluminium, it is very important that the windlass is insulated from the deck with a timber pad or non-conductive gasket. Fixings should pass through the insulators provided and under deck fixings are also insulated from the deck. It is also important that the anchor and chain is insulated from the hull, including rubber lining, the chain locker and insulating the fixing for the end of the chain to the hull.

Without these precautions severe electrolysis can occur.

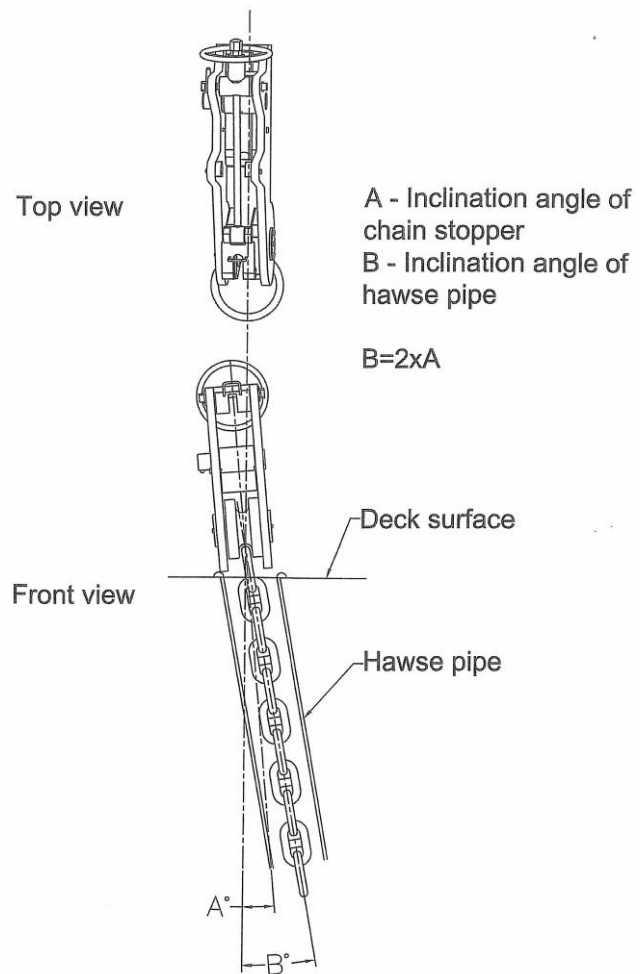

Picture 2.3
Installation angle of chain stopper

2.4 INSTALLING THE WINDLASS

Refer to the drawing in Appendix B for help with identifying components and installing them correctly.

- Remove windlass from its packing case.
- Make sure the mounting area on the deck is properly prepared, as per step 3 above and is clean.
- Clean the underside of the windlass case.
- Use sealant/bedding compound between deck, pad/gasket and the windlass case and lower the windlass, aligning the mounting holes in the case with the pre drilled mounting holes in the deck and bed the windlass down.
- Make sure that the four insulating bushes are in place in the mounting holes in the case.
- Stainless steel washers should be used under the head of the mounting bolts to spread the load on the insulating bushes.
- Apply a little sealing compound to the four mounting bolts and feed the bolts down through the bushes in the case and deck.
- From the underside of the deck offer up the clamp plates or large washers and fix in place with the nuts.
- The chainpipes should now be fitted. If the deck is steel or aluminium the chainpipe and fastenings also must be insulated from the deck. The chainpipes must be through bolted using 316 stainless steel countersunk screws with the nuts under deck backed up with large stainless steel washers. When fixing, ensure that the stripper arms are aligned squarely in the groove of the chainwheel with the bevelled end in close proximity to but clear of the root of the groove. The chain must pass over the wheel and cleanly through the pipe without fouling on the stripper.

! Extra care should be exercised when handling polished parts to avoid any damage to polished surfaces.

! Tighten the nuts progressively and evenly. DO NOT USE POWER TOOLS. Do not over tighten. Ensure installation is firm.

2.5 POWER CONECTIONS TO DC MOTOR

The main power system is a two cable, ungrounded, fully insulated, negative return system. The motor is of the isolated earth type. This system is selected to minimise electrolytic corrosion problems.

The DC motor has three power terminals, marked "F1", "-", and "F2". Terminal "-" should be connected directly to "-" terminal on the battery, see wiring schematic in Appendix C. Terminal "F1" and "F2" should be connected to solenoids. Depending on the desired direction of rotation, these terminals may need to be swapped around.

See Table 2.1 to select the appropriate cable size for power supply. The recommendation assumes that the cable insulation has a minimum temperature rating of 90°C and sizes allow for a maximum 10% voltage drop over the total length.

Cable lengths given are from the battery terminal to the terminal on the motor, via the solenoid box, and then back to the battery.

Where a portion of cable runs through the engine room, a size increase should be made as indicated.

After connecting the cables, spray all terminals with

! When tightening the cables to the motor, ensure the lower nut is secure against turning when tightening the upper nut. This will prevent damage occurring within the motor.

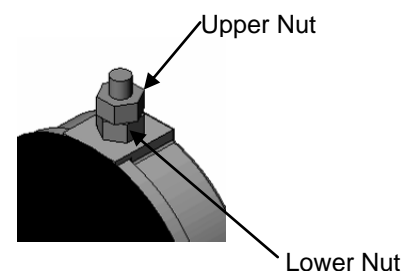

Picture 2.4
Motor Connections

anti-corrosive waterproof coating, "CRC 3013 Soft Seal" or equivalent.

12V Systems				
Total Cable Length from battery to winch then back to battery	Wire Size		Engine Room Wire Size Correction *	
	mm ²	AWG	mm ²	AWG
Up to 12.2m (40')	34	2	42	1
From 12.2m – 15.3m (40' - 50')	42	1	-	-
From 15.3m – 21.4m (50' - 70')	54	0	-	-
From 21.4m – 24.4m (70' - 80')	67	00	-	-
From 24.4m – 30.6m (80' - 100')	85	000	-	-
24V Systems				
Total Cable Length from battery to winch then back to battery	Wire Size		Engine Room Wire Size Correction*	
	mm ²	AWG	mm ²	AWG
Up to 18.3m (60')	14	6	16	5
From 18.3m – 30.6m (60' - 100')	22	4	-	-

Table 2.1
Recommended wire sizes

2.6 POWER CONNECTION TO HYDRAULIC MOTORS

A basic hydraulic schematic is shown in Appendix C. Port sizes on the hydraulic motor and minimum hose sizes are specified in Section 1.3.

The motor has pressure and return ports. The pressure and return ports should be connected to a solenoid controlled valve (not supplied by Maxwell). After connecting the power lines, spray all ports and fittings with anti-corrosive waterproof coating, "CRC 3013 Soft Seal" or equivalent.

2.7 INSTALLATION OF CONTROLS

The windlass can be operated using:

- Deck mounted footswitches
- Hand held pendant controller (single or dual speed)
- Helm switch
- Chain counter

These control accessories are available from Maxwell customised to suit your windlass.

It is the choice of the designer/builder to use one, two or all four of these controls. They are wired in parallel to the directional valve (for hydraulic windlasses) or to the starter unit (for electric windlasses). The controls can work on 12 or 24V

power supply.

If footswitches are used, then an isolator switch for them must be installed in the wheelhouse, to prevent operating the windlass by someone accidentally stepping on the footswitch.

Hand held pendant controller is often the most convenient way of operating the windlass. Maxwell offers several variations of pendants, including single speed, dual speed, single pendant for running a pair of windlasses, pendants with auxiliary buttons which can be used for starting chain wash system, hydraulic pump etc. They are supplied with a plug on the other end of cable and a matching waterproof socket, which should be installed on a convenient location on the deck.

All units are supplied with detailed wiring instructions to assist installation.

Refer to wiring schematics in Appendix C for control circuits. All control wiring should be done using no smaller than 1.5mm² wire (AWG 16).

A manually re-settable, ignition proof 3A breaker or fuse should be installed on the power supply line for controls, within 1m (40") from the main breaker/isolator. These requirements are mandatory to meet USCG, ABYC and NMMA rules.

After connecting the power lines, spray all ports and fittings with anti-corrosive waterproof coating "CRC 3013 Soft Seal" or equivalent.



Picture 2.9

Pendant controller for operating two windlasses

2.8 NOTE TO BOAT BUILDER

Experience has shown that, on long ocean deliveries, sulphur from the ship's exhaust can settle on polished surfaces, which can affect the quality of the finish.

Please ensure that, upon completion of installation, the windlass is treated with suitable corrosion protective coating ("CRC 3097 Long Life") and wrapped in plastic film. This ensures that your customer receives the windlass from you in the same top quality condition as you received it from Maxwell.

3.0 USING THE WINDLASS

3.1 PERSONAL SAFETY WARNINGS

- As with all load carrying equipment, the consequences of heavy overload, neglect or misuse may be unexpected failure and exposure of crew and/or vessel to risk. Operate the windlass with extreme care at all times.
- Before testing the windlass for the first time, check that all the wiring has been done correctly.
- When using the windlass at all times practice good seamanship and adhere to the following rules in order to avoid any likelihood of injury or accident.
- At all times keep hands, feet, loose clothing,

cordage and your hair WELL CLEAR.

- Never operate the windlass from a remote station without maintaining a clear view of it and having made sure that everyone is well clear of the windlass, anchor and chain.
- Never use the windlass under power with the clutch handle inserted into clutch nut or emergency crank collar.
- Never engage the Pawl while chain is running.
- Always motor up to the anchor position before retrieving it from the bottom. Do not use the windlass to pull the boat to the anchor.
- If the anchor is fouled, do not use the windlass to break it out. With the chain stopper taking the load, use the boat's engine to break the anchor loose.
- When lowering the anchor under manual control, use the friction clutch (if fitted) to control the speed of the chain. Never lower the anchor without maintaining safe chain speed.
- When the windlass is not in use, make sure the power supply is isolated, making an accidental operation thereby impossible.
- Do not use the windlass as an anchoring point for the chain. Engage the chain stopper when the windlass is not in operation.
- Never proceed at speed without first ensuring that the chain stopper is engaged. Also engage the tensioner to keep the anchor snug in the pocket.
- When using the windlass, do not switch immediately from one direction of rotation to the other, without waiting for windlass to stop. Abuse is not covered by warranty.
- When lowering the anchor under power take care not to overspeed the windlass, overspeed can occur when anchoring in deep water and using heavy tackle. If anchoring in deep water it is preferable to manually deploy the anchor.

3.2 LOWERING THE ANCHOR UNDER POWER

- Ensure the clutch is fully engaged by inserting the clutch nut lever in one of the slots on the clutch nut, and turning clockwise firmly. The windlass is equipped with a friction clutch, so it can be engaged in any position (there is no need to match the position of the opposite sides of the clutch before engaging it).
- Remove clutch handle.
- Release pawl.
- Disengage chain stopper and chain tensioner (if fitted). To disengage the chain stopper pawl the windlass may require momentary jogging in the up direction.
- The windlass may now be lowered under power by operating either the hand held pendant control, helm switch or footswitch.
- When finished, turn off the isolator switch for the controls.

! As a safety feature the windlass will continue to operate up or down only while the operating button, toggle switch or foot switch is held in the engaged position.

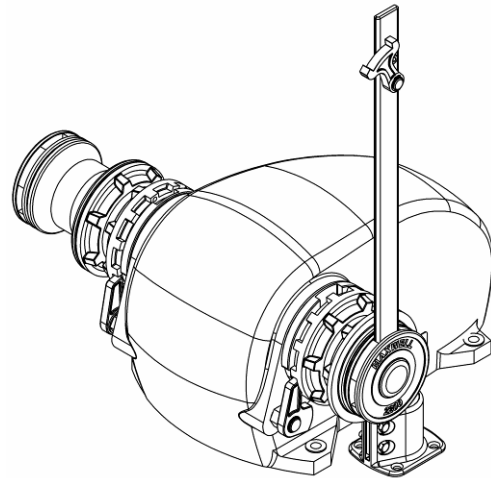

Picture 3.1
Engaging the clutch

3.3 RETRIEVING THE ANCHOR UNDER POWER

- Ensure clutch is engaged and pawl is released.
- Remove clutch handle.
- Release chain stopper and/or tensioner (if fitted).
- The windlass may now be operated to raise the anchor.
- After retrieving the anchor engage chain stopper and/or tensioner (if fitted).
- Turn off the isolator switch for the controls.

! It is regarded as sound practice to motor over the anchor position and so reduce chain tension. This will also help the anchor to break out, reduce the power consumption and reduce load on the windlass and deck gear.

! Care should be exercised when docking the anchor to avoid damage to the anchor pocket. Jog in the last meter (3-4') of the chain carefully seating the anchor home.

3.4 LOWERING THE ANCHOR UNDER MANUAL CONTROL

This method will normally be employed to lower the anchor quickly, to lower it in "quiet ship" and in emergencies (power loss or control failure).

Proceed as follows:

- Tighten the clutch.
- Release the chain stopper and/or chain tensioner (if fitted). If the anchor has to be lowered in case of power loss and pawl on the chain stopper is engaged and under tension (by chain), to release it, pull the chain in slightly, either by power or manually. If there is too much slack in the chain, it might be necessary to jog the windlass up under power or use the emergency crank lever. If doing that, make sure the clutch is still engaged, for safety reasons.
- Slowly disengage the clutch by turning the clutch nut anticlockwise. Regulate the speed by tightening to slow (clockwise) or easing (anticlockwise) to increase speed
- When the required amount of chain is out, tighten the clutch nut firmly.

! It is considered potentially dangerous to allow the chain to free fall in an unrestricted manner - always control the chain speed.

! If jogging under power, ensure the lever is removed first.

3.5 RETRIEVING THE ANCHOR UNDER MANUAL CONTROL

The windlass is equipped with a cranking mechanism to retrieve the anchor in case of emergency. It involves operating the windlass manually under heavy load and extra care must be exercised when using it to avoid injury.

To use proceed as follows:

- Check that the chain stopper is engaged. If a chain stopper is not fitted, ensure that the pawl is engaged with the chainwheel.
- Insert the clutch nut lever in the clutch nut and release clutch by turning the clutch nut in anticlockwise direction.
- Insert the clutch nut lever (the end with the pawl) into the emergency crank collar and engage the pawl with one of the dogs in the chainwheel in the furthest forward position (Picture 3.2).
- Pull the lever back as far as possible, bringing the chain in. Engage the pawl and ease off the lever.
- Push lever to furthest forward position and re-engage with the chainwheel.
- Repeat the cycle until the anchor is retrieved. It is a very slow process and should be used only in emergencies.

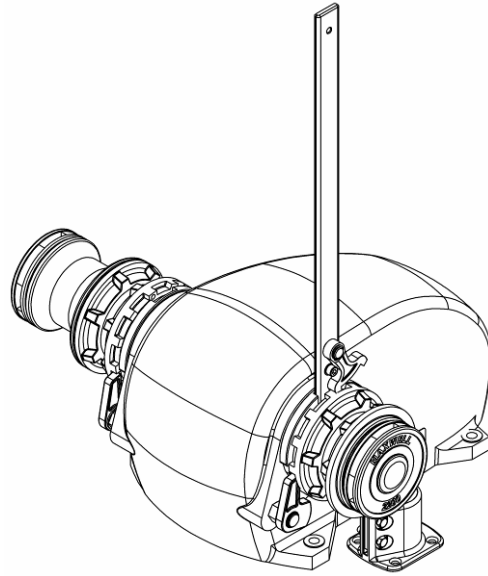

Picture 3.2
Using emergency crank mechanism

3.6 OPERATING THE HORIZONTAL WARPING DRUM INDEPENDENTLY (if fitted)

Maxwell recommends all warping operations be controlled by the footswitch. This makes it a one-person operation and offers better control of the capstan in case of emergency.

The drum can be operated independently of the chainwheel and can be used to manage docking lines or a second anchor. To use in this way, proceed as follows:

- Engage the chain stopper (if fitted) and/or the pawl.
- Slowly disengage the clutch by turning the clutch nut anticlockwise.

The drum may now be operated independently of the chainwheel.

Take several turns of the warping line around the drum and pull on the rope tail with sufficient manual force to provide good grip of the line to the drum, whilst operating the footswitch. Make sure the drum is operated in the same direction as the line is wrapped around it.

Do not engage more turns on the drum than are necessary to accomplish the task. Whilst docking, wind and tide can impose sudden and excessive line tension. It is recommended to allow slipping to occur at the drum. This will protect the capstan, docking lines and vessel from damage.

- ! While handling docking lines with the capstan, everybody has to stay well clear of the lines and the capstan.
- ! Take care not to allow “riding turns”. This is caused by the loaded line climbing on top of lower loaded coils. A riding turn can only be removed by paying out to the point where the riding turn is removed.

4.0 MAINTENANCE

4.1 EVERY TRIP

Ensure clutch is correctly engaged.

The parts external of the case should be washed down with fresh water at the end of every trip.

4.2 EVERY THREE MONTHS

Disassemble all the components of the windlass (external of the case) as described in Section 5.1. Clean all components and check for damage. Grease the components using lithium complex base, water proof grease, especially clean and re-grease the conical surface on both clutch cones and mating faces of gypsy (chainwheel) , as shown on Picture 5.2.

Clean chromed surfaces with a cloth, damp with kerosene. After cleaning spray them with "CRC 3037 Long Life" or alternatively, with "CRC 6-66" or "WD-40". Regular use of "CRC3097 Long Life" will assist in maintaining the bright chrome finish.

Re-assemble in the reversed order.

Inspect the components below deck for corrosion, chipped paint etc, clean them, and touch up the paint if necessary. Spray them for protection with "CRC 3013 Soft Seal".

4.3 EVERY YEAR

Carry out the Three Monthly Maintenance and:

Remove gearbox/spacer tube and motor, as described in Section 5.2. Ensure drainage slots are free from debris by flushing with fresh cold water.

Remove DC motor and service. Replacement brush sets are available:

Part No. P100807 – 12V

Part No. P100808 – 24V

4.4 EVERY 3 YEARS

Carry out the yearly maintenance and:

Remove spacer tube from the gearbox, clean it (as well as top of the gearbox) and apply Res-Q-Steel on mating faces.

Have the Gearbox serviced at an authorised Maxwell service agent

4.5 RECOMMENDED LUBRICANTS

Greases

- Lithium complex base NLG1 consistency No. 2

- CASTROL LMX
- DUCKHAMS Keenol
- FINA CERAN WR 2
- SHELL Retinex LX
- MOBIL Mobilgrease HP

! Never mix greases, use only one type. If in doubt, remove the previous lubricant and clean the parts thoroughly before applying the new one.

Gearbox Oils

- ISO 3448 VG 320

- CASTROL Alpha MAX 320
- SHELL Tivela oil SC320
- MOBIL Mobilgear 632
- BP MACH GR XP 320

Note Gearbox fill quantity = 350ml

! Never mix different types of oil, even if they are from the same manufacturer.

Anti-Corrosive Coatings

- CRC 3013 Soft Seal
- Boeshield T9
- Lanocote

Anti-Seize Coating

- International Paints Res-Q-Steel

5.0 DISASSEMBLING THE WINDLASS

5.1 REMOVAL OF PARTS EXTERNAL OF CASE

- If supplied, remove stripper arm (30) from chainpipe (31), by undoing two bolts, nuts and washers (29,32,33).
- With a pen knife, or similar, carefully remove cap (1).
- Remove screw (2) and retaining washer (3).

! Extra care should be exercised when handling polished parts to avoid any damage to polished surfaces.

For Horizontal Drum only:

- Remove the drum (6) and key (35).
- Remove 2 retention clips (10) from shaft (36).

For Chainwheel only:

- Unscrew clutch nut (5).
- Slide outer clutch cone (7), chainwheel (9) and inner clutch cone (7) complete with disc springs (8) from shaft.
- Remove key (35), 2 retention clips (10), washer (11) and spring (12) from shaft (36).
- Slide emergency crank collar (13) from shaft.
- If disassembly from the port side there will be an extra spring (12), beneath the emergency crank collar (13), to remove.

For Horizontal Drum and chainwheel:

- Unscrew clutch nut (5).
- Remove the drum (6) and key (35).
- Slide outer clutch cone (7), chainwheel (9) and inner clutch cone (7) complete with disc springs (8) from shaft.
- Remove key (35), 2 retention clips (10), washer (11) and spring (12) from shaft (36).
- Slide emergency crank collar (13) from shaft.
- If disassembly from the port side there will be an extra spring (12), beneath the emergency crank collar (13), to remove.

5.2 REMOVAL OF PARTS INTERNAL OF CASE

Unless there is adequate room under the deck, to access the internal parts, it may be necessary to unbolt the windlass and raise it to a workable height.

For Horizontal Drive:

- Remove cables/hoses from the motor.
- Remove the shaft by releasing 2 circlips (34) and sliding the shaft through the gearbox and case bearing (14).
- While supporting the gearbox and motor, remove Bolts and washers(26,27,28).The gearbox and motor should drop down
- Undo the motor from the gearbox by removing motor bolts (40) washers (41,42,44) and nuts (45) (if applicable)

! Depending on the situation, the motor can be removed prior to gearbox.

5.3 ASSEMBLY OF PARTS

When assembling the parts, apply an anti-seize compound generously over all screw threads, keys and keyways, main shaft and inside the spacer tube. See section 4.5 for recommended lubricants.

When applicable, assembly the horizontal and/or vertical shaft, gearbox and motor in the reverse order of disassembly explained in section 5.2

For Horizontal Drum only:

- Apply anti-seize compound generously over the main shaft and keyway.
- Insert key (35) and 2 retention clips (10). Apply some grease to help keep them in position.
- Assemble drum (6).
- Put retaining washer (4) on top of the main shaft and secure it with the countersunk screw (3).
- Insert plastic cap (1) into the clutch nut.

For Chainwheel only:

- If assembling on the port side there will be an extra spring (12), beneath the emergency crank collar (13), to assembly first on the shaft (36).
- Slide emergency crank collar (13) into shaft, followed by the spring (12) and washer (11).
- Apply anti-seize compound generously over the main shaft and keyway.
- Insert key (35) and 2 retention clips (10). Apply some grease to help keep them in position.
- Assemble the lower clutch cone (7) making sure it sits nicely on the retention clips (picture 5.1). Apply lithium based marine grease generously to the conical surface of the clutch cone and to the mating surfaces of gypsy (chainwheel), to assist with free falling the anchor.
- Put the disc spring (8) on top of the lower clutch cone (7), turning its smaller diameter towards the clutch cone (picture 5.2).
- Install chainwheel (9) and the remaining disc spring (8) on top of it, turning its bigger diameter towards the chainwheel (picture 5.2).
- Install outer clutch cone (7), after applying marine grease to its conical surface (picture 5.2).
- Assemble clutch nut (5).
- Put retaining washer (4) on top of the main shaft and secure it with the countersunk screw (3).
- Insert plastic cap (1) into the clutch nut.

For Horizontal Drum and chainwheel:

- If assembling on the port side there will be an extra spring (12), beneath the emergency crank collar (13), to assembly first on the shaft (36).
- Slide emergency crank collar (13) into shaft, followed by the spring (12) and washer (11).
- Apply anti-seize compound generously over the main shaft and keyway.
- Insert key (35) and 2 retention clips (10). Apply some grease to help keep them in position.

! Extra care should be exercised when handling polished parts to avoid any damage to polished surfaces.

! When assembling the windlass, the shaft, bronze clutch cones and capstan MUST be coated in Shell Nautilus NLG12 Marine Grease, Castrol Boating Grease, Vavoline Val Plex EP or equivalent grease.

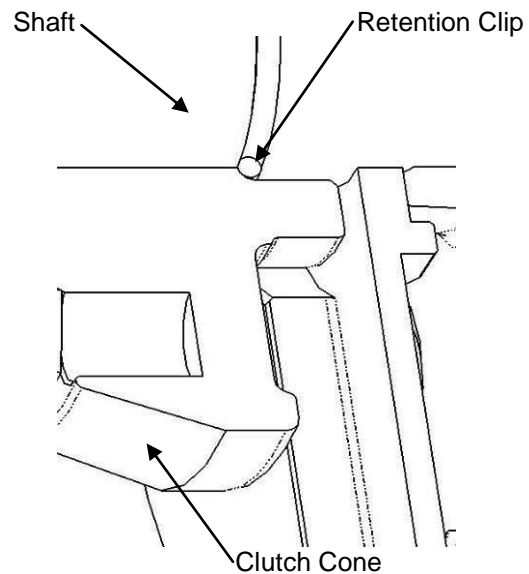

Picture 5.1
Retention Clip Assembly

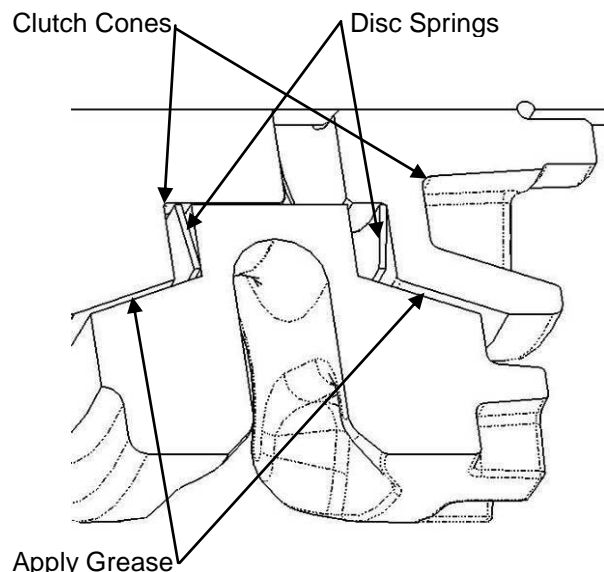

Picture 5.2
Greasing clutch cones and disc spring orientation

- Assemble the inner clutch cone (7) making sure it sits nicely on the retention clips (picture 5.1). Apply lithium based marine grease generously to the conical surface of the clutch cone, to assist with free falling the anchor.
- Put the disc spring (8) on top of the inner clutch cone (7), turning its smaller diameter towards the clutch cone (picture 5.2).
- Install chainwheel (9) and the remaining disc spring (8) on top of it, turning its bigger diameter towards the chainwheel (picture 5.2).
- Install the outer clutch cone (7), after applying marine grease to its conical surface (picture 5.2).
- Assemble drum (6) on top of the clutch cone.
- Assemble clutch nut (5).
- Put retaining washer (4) on top of the main shaft and secure it with the countersunk screw (3).
- Insert plastic cap (1) into the clutch nut.

5.4 SPARE PARTS

Maxwell recommends a modest quantity of spare parts to be ordered as familiarity with the windlass is developed during installation. Frequently smaller parts are lost during maintenance, so keeping spares (and spare tools) is recommended.

We recommend the following list of spare parts to be carried on board:

Part no.	Description	Qty
3227	Plastic Cap	1
5953	Disc Spring	2
2311	Retention Clip	2
3207	Key - Topworks	2
3150	Key - Gearbox	1
7068	Washer	1
2310	Spring	1
SP0846	Circlip	2
SP2787	O-Ring – Elect Motor	1

If you need any other spare part, please refer to the Appendix B for the correct part number and contact one of our distributors worldwide (Appendix E). When ordering spare parts, please also quote the serial number of the windlass.

5.5 TOOLS FOR MAINTENANCE

We recommend the following tools be kept on board for disassembling and assembling the windlass:

- Set of metric hexagon keys
- Ring / open end spanner 13, 17, 19mm and 9/16"
- Flat screw driver 10mm blade width
- Circlip pliers

6.0 TROUBLESHOOTING

Problem	Possible Cause	Solution
The windlass does not move.	No electric power to controls.	Make sure the isolator switch for windlass controls is ON.
		Check the fuse on power supply to controls.
		Make sure the wiring is correct and check it for damage.
		If there is more than one type of control (pendant unit, footswitch, helm switch), check them all in an effort to isolate the problem.
	Check the power supply to controls from the source, step by step, and identify the point where it stops.	
	Incorrect or incomplete wiring.	Check wiring against diagrams supplied.
	No power supply to the windlass.	Check power supply lines.
		Check main isolator switch.
		Check hydraulic pump.
Windlass is not able to pull the specified load.	Motor voltage does not match the power supply on board.	Check name plate on the motor. If confirmed, contact Maxwell.
	Hydraulic relief valve not set correctly.	Check valve setting.
DC motor draws high current but struggles to pull the load.	The mounting bolts of the motor are touching the motor winding.	Make sure the bolts have spring washers, adjust bolt length.
Windlass runs but the chainwheel stays stationary.	Windlass runs but the chainwheel stays stationary.	Tighten the clutch up, as described in Section 3.2. If the problem persists, contact Maxwell.
	Chainwheel/drum keys (35) not installed.	Install the key.
Electric motor stops after prolonged heavy use.	The motor has been overloaded and has reached its critical temperature.	Leave it to cool down and reset the circuit breaker.
The anchor does not free fall.	The clutch cones are not greased.	Disassemble the clutch cones (7), clean and grease them as described in Section 4.2.
	The clutch is not fully disengaged.	Disengage the clutch fully.
	Disc springs (8) not fitted.	Fit disc springs as described in Section 5.3.
	Pawl (20) engaged.	Disengage pawl.
Chain jumps / slips on the chainwheel.	The chainwheel not selected correctly.	Contact Maxwell with correct identification of the chain used on board.
	Chain twisted between windlass and bow roller.	Untwist the chain.
	Horizontal angle of incoming chain bigger than 2 degrees (Picture 2.2)	Check the installation. If the problem persists, some adjustments might have to be made.

APPENDIX A - Dimensional Drawings

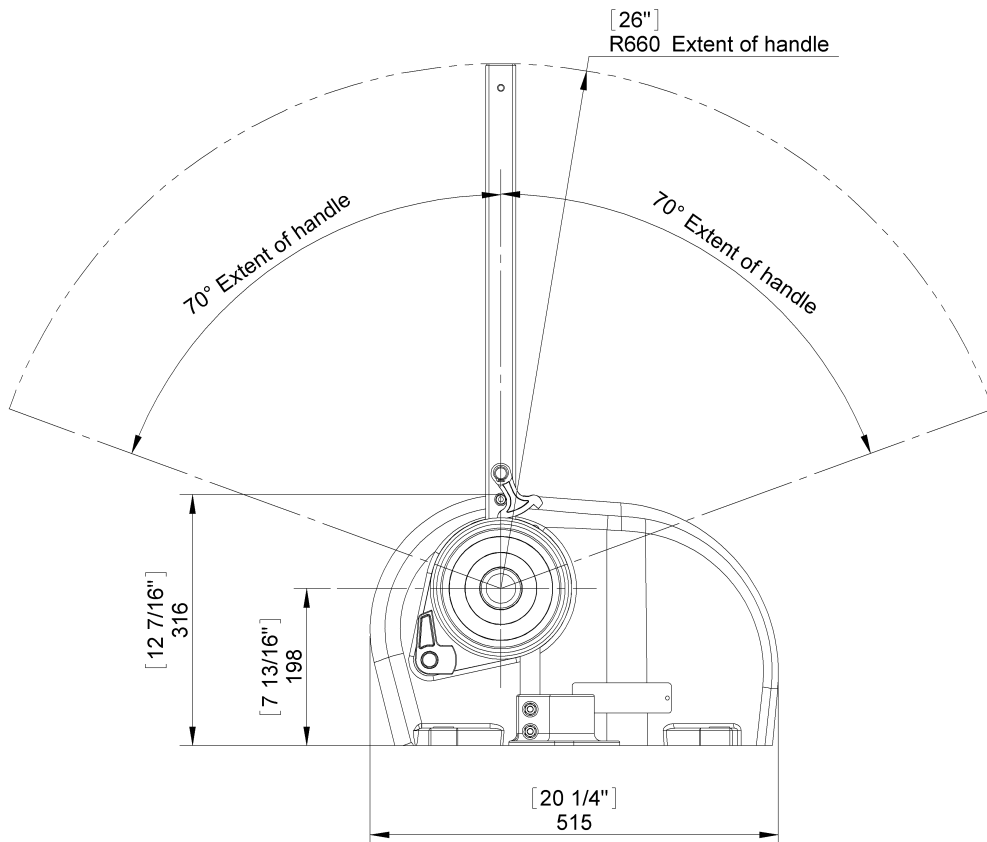
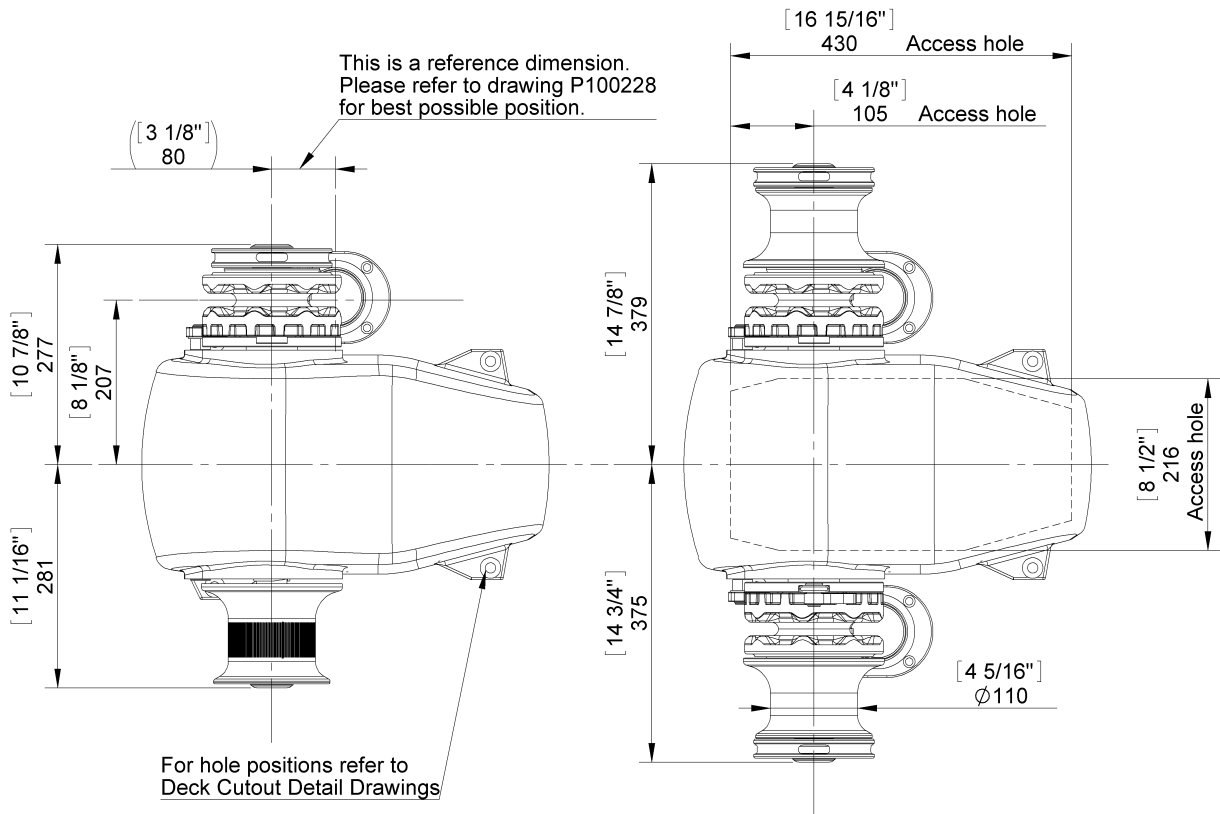

Note:

These are all typical dimensions, depending on which model has been purchased.

This drawing is protected by copyright and the design and or details contained therein are the confidential property of MAXWELL MARINE LTD.
 This drawing must be returned upon demand and must not be copied, loaned or have its contents communicated to any other persons, including subcontractors, without the consent in writing from Maxwell Marine Ltd. This drawing must not be used for any other purpose other than that for which it was originally supplied.

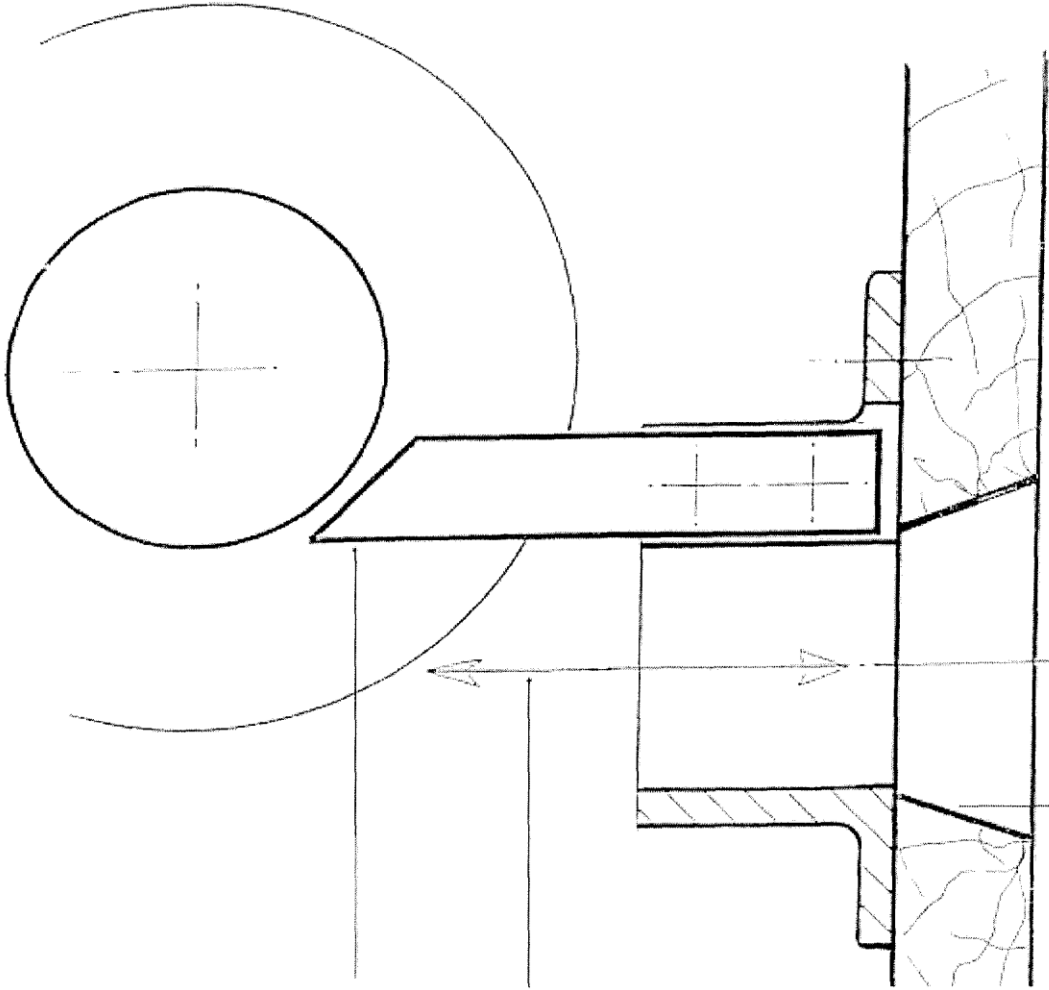

Stripper should not be intruding into the inner diameter of the chainpipe

Chain should be feeding through the centre and not be coming into contact with the walls of the pipe or stripper when powering out.

A swivel mounted between anchor and chain will also prevent unnecessary twist

Deck through hole should have greater diameter than chainpipe and flare away beneath the deck

BVT/Dwg No.	
BVT View	
Sheet Size	Scale
A4	NTS
Sheet 1 of 1	

Revision	Change	Made on	Des/Drawn
1.00	Initial Issue	5/10/2004	RP

BVT/Dwg No.	
Description	HWC Chainpipe Installation
Assy No.	P100228

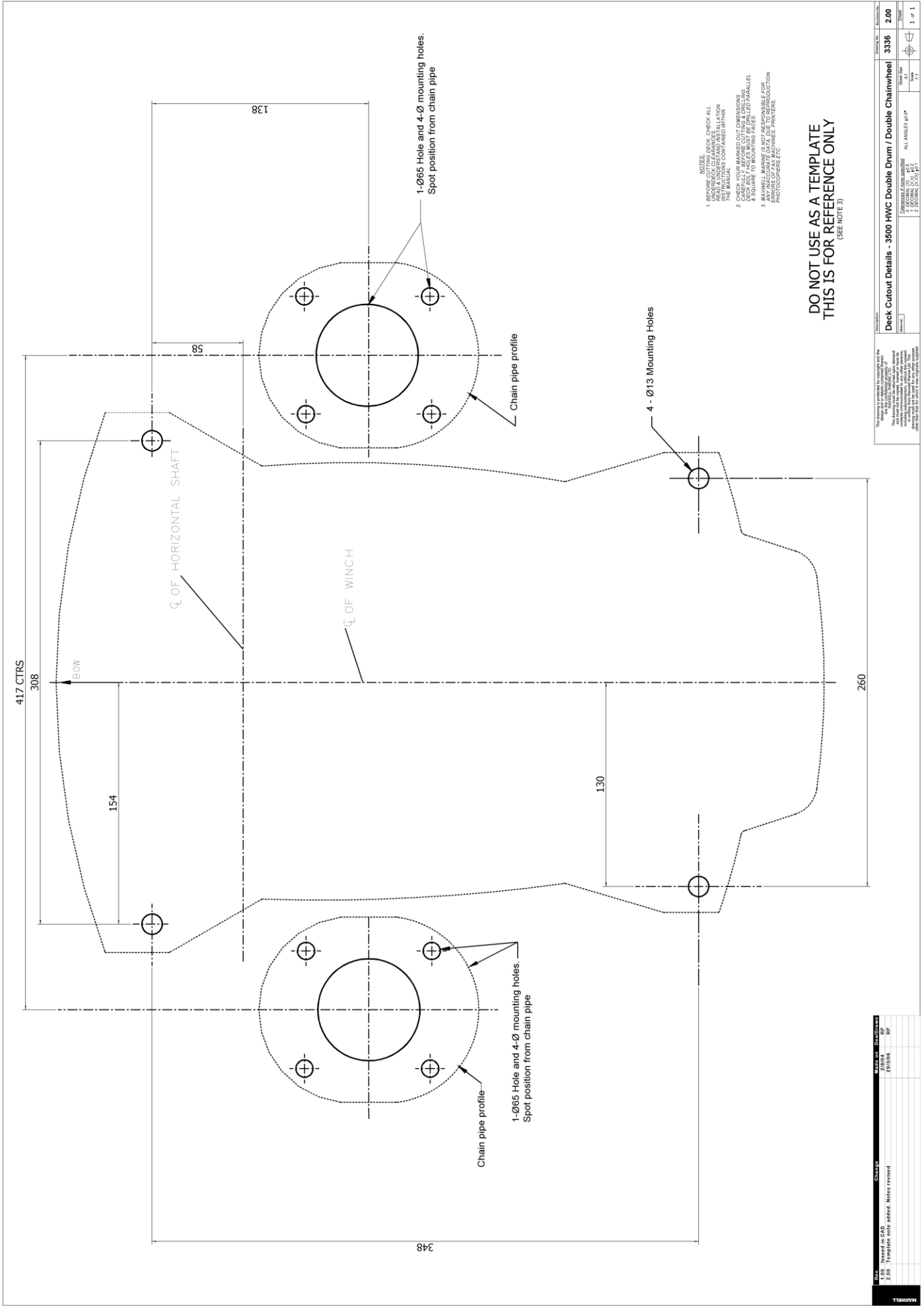

- NOTES:**
1. BEFORE CHECK, CHECK ALL DIMENSIONS, CLEARANCES, ALLOWANCES, AND TOLERANCES CONTAINED WITHIN THE DRAWING.
 2. CHECK YOUR MARKED OUT DIMENSIONS AND SPACING. ALL DIMENSIONS ARE TO BE TAKEN FROM THE FACE UNLESS SPECIFIED OTHERWISE.
 3. ANY VARIATIONS IN DIMENSIONS, DIMENSIONS, OR TOLERANCES MUST BE APPROVED BY THE DESIGNER BEFORE PROCEEDING WITH FABRICATION.

**DO NOT USE AS A TEMPLATE
THIS IS FOR REFERENCE ONLY**
(SEE NOTE 3)

REV	DATE	BY	CHKD	DESCRIPTION
1.00	12/04/2010	RP	RP	ISSUED FOR FABRICATION
2.00	26/05/2010	RP	RP	NOTES REVISED

PROJECT NO.	3336
ISSUE NO.	1
TITLE	Deck Cutout Details - 3500 HWC Double Drum / Double Chainwheel
DRAWN BY	RP
CHECKED BY	RP
SCALE	1:1
DATE	26/05/2010
PROJECT	ALL ANGLES 8° R/A
1	1 OF 1

This drawing is protected by copyright and the design and/or details contained therein are the confidential property of MAXWELL MARINE LTD. This drawing is not to be copied, altered and must not be copied, loaned or have its contents communicated to any other persons, including subcontractors, without the consent of Maxwell Marine Ltd. This drawing and drawing must not be used for any other purpose other than that for which it was originally supplied.

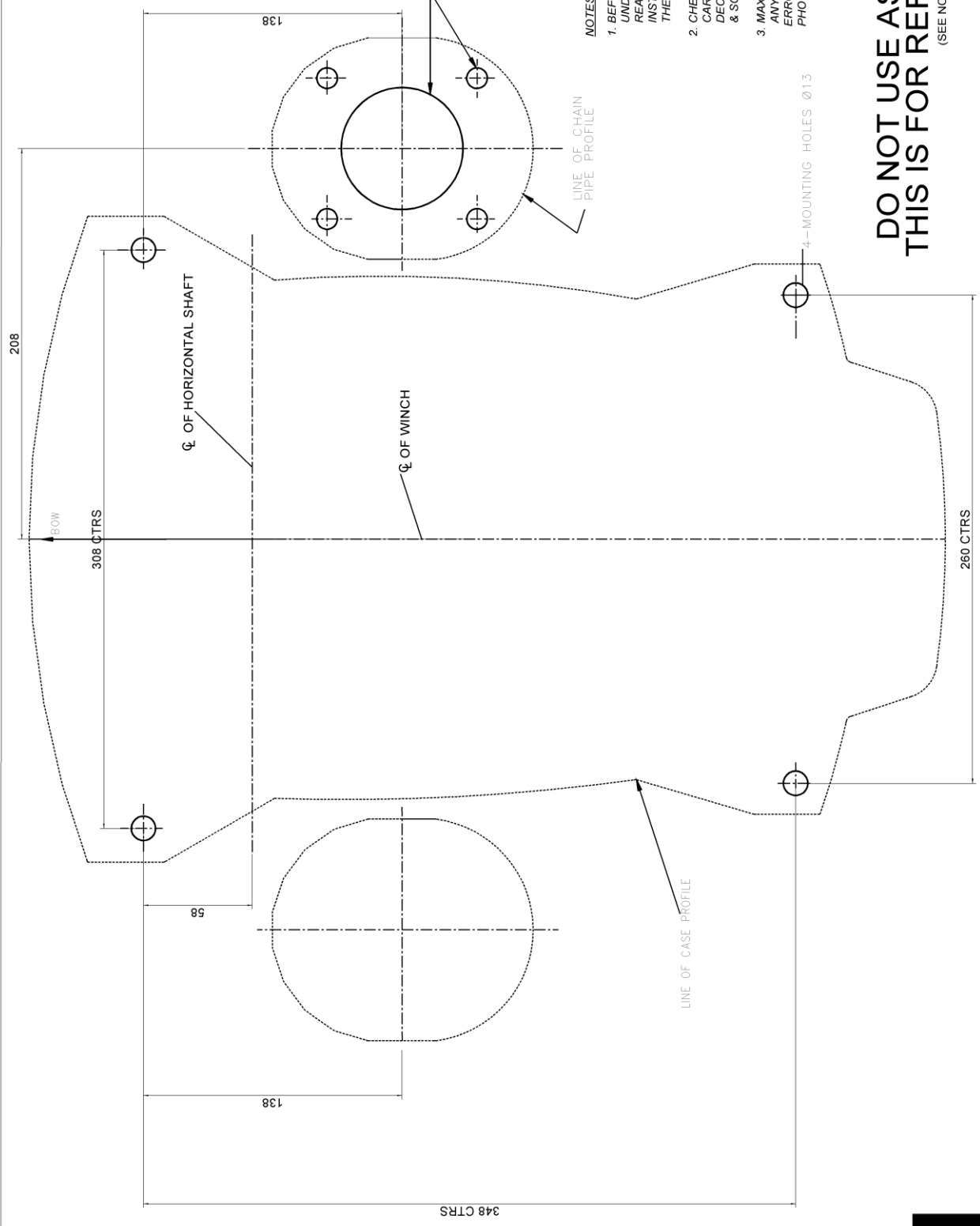

NOTES.

1. BEFORE CUTTING DECK, CHECK ALL UNDERDECK CLEARANCES. READ & UNDERSTAND INSTALLATION INSTRUCTIONS CONTAINED WITHIN THE MANUAL.
2. CHECK YOUR MARKED OUT DIMENSIONS CAREFULLY, BEFORE CUTTING & DRILLING. DECK BOLT HOLES MUST BE DRILLED PARALLEL & SQUARE TO MOUNTING FACES.
3. MAXWELL MARINE IS NOT RESPONSIBLE FOR ANY INACCURATE DATA, DUE TO REPRODUCTION ERRORS OF FAX, MACHINES, PRINTERS, PHOTOCOPIERS ETC.

**DO NOT USE AS A TEMPLATE
THIS IS FOR REFERENCE ONLY**
(SEE NOTE 3)

FOR INSTALLATION DRAWINGS REFER TO B203082

Description	Drawn:	Date:	Scale:	Revision No:
Deck Cutout Details - 3500 HWC Single Drum and chainwheel	AH	03/08/04	A4 = 1:3 A1 = 1:1	3429 2.00



APPENDIX B – Spare Parts

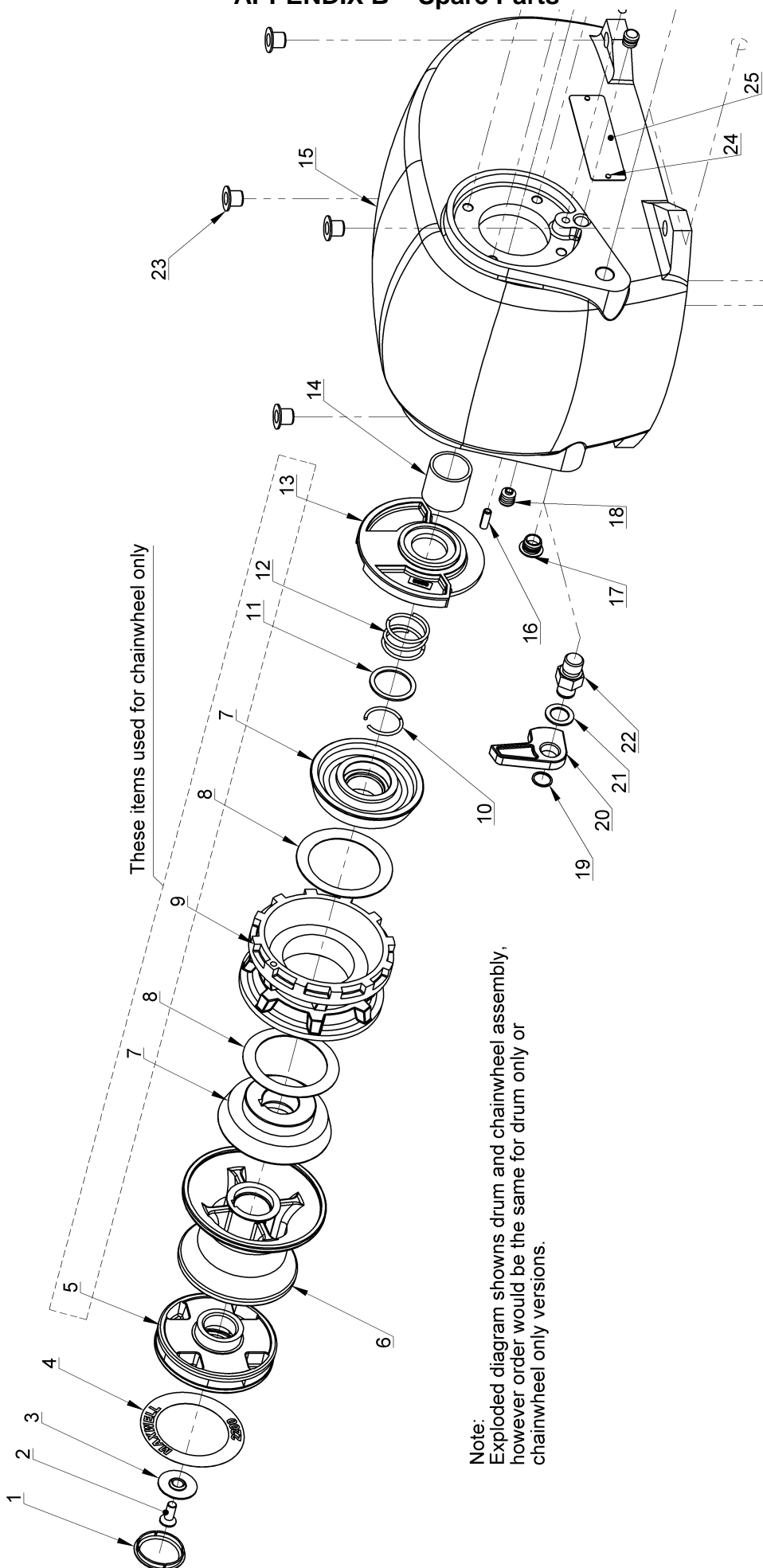

Note:
Exploded diagram shows drum and chainwheel assembly,
however order would be the same for drum only or
chainwheel only versions.

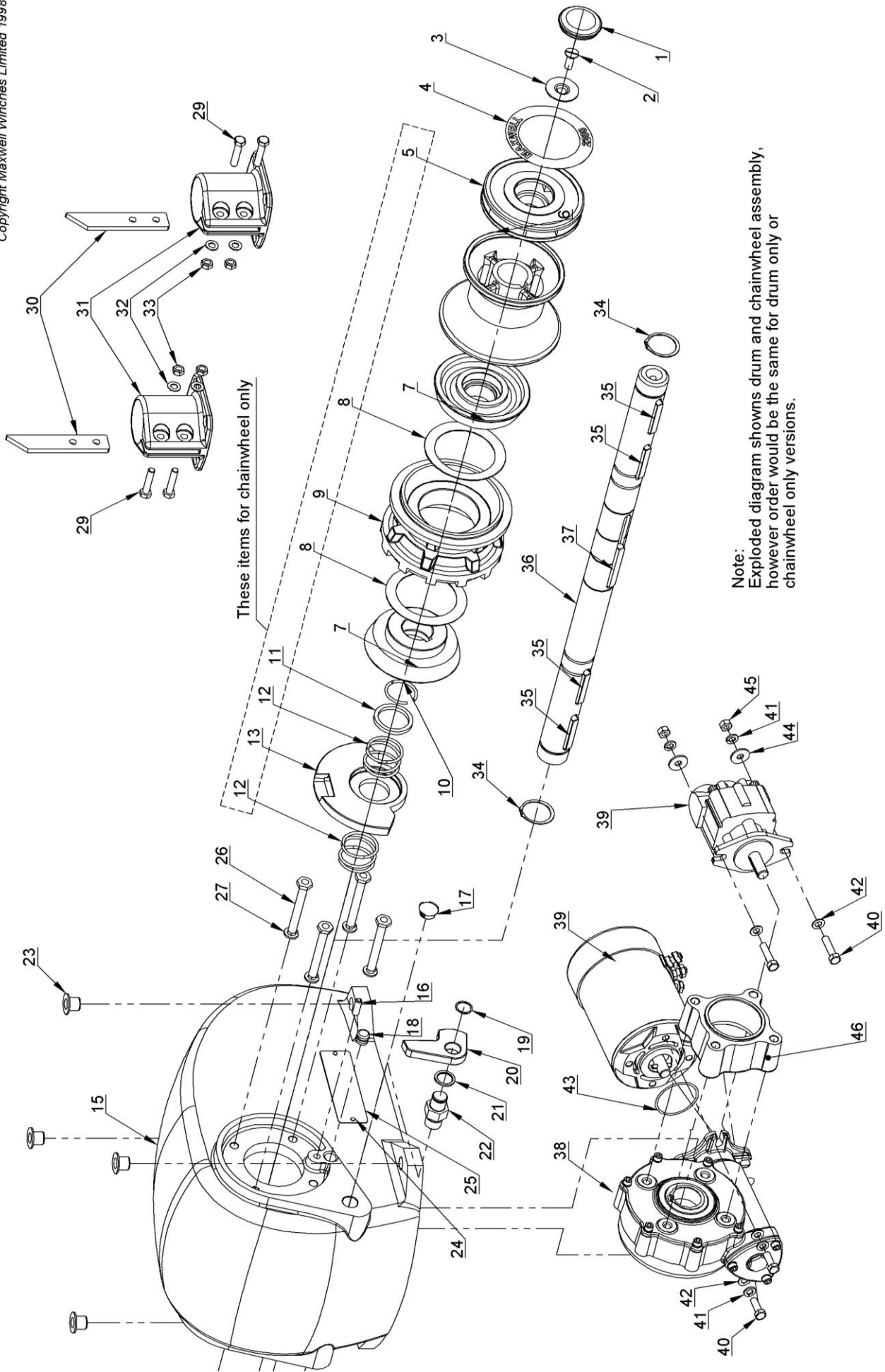

Item	Description	Qty	Part no.
1	Plastic cap	2	3227
2	Countersunk screw 3/8"	2	SP0040
3	Retaining washer	2	3267
4	Label	2	3856
5	Clutch nut	0	
	– No Chainwheel	1	3181C
	– Chainwheel Port or Starboard side only	2	3181C
	– Chainwheel Port and Starboard side		
6	Drum - Horizontal		
	– Port or Starboard side only	1	3303C
	– Port and Starboard side	2	3303C
	– Port or Starboard side only with chainwheel	1	2304C
	– Port and Starboard side with chainwheel	2	2304C
7	Clutch cones	0	
	– No Chainwheel	2	6061
	– Chainwheel Port or Starboard side only	4	6061
	– Chainwheel Port and Starboard side		
8	Disc Spring	0	
	– No Chainwheel	2	5953
	– Chainwheel Port or Starboard side only	4	5953
	– Chainwheel Port and Starboard side		
9	Chainwheel		
	– Port or Starboard side only	1	3182
	– Port and Starboard side	2	3182
10	Retention clip	4	2311
11	Washer		
	– No Chainwheel	0	
	– Chainwheel Port or Starboard side only	1	7068
	– Chainwheel Port and Starboard side	2	7068
12	Spring		
	– No Chainwheel	0	
	– Chainwheel Port side only	2	2310
	– Chainwheel Starboard side only	1	2310
	– Port and Starboard side	3	2310
13	Emergency crank collar		
	– No Chainwheel	0	
	– Chainwheel Port or Starboard side only	1	3158
	– Chainwheel Port and Starboard side	2	3158
14	Bearing –Dixon	1	SP0657
15	Case	1	3294
16	Stop pin		
	– No Chainwheel	0	
	– Chainwheel Port or Starboard side only	1	SP0544
	– Chainwheel Port and Starboard side	2	SP0544
17	Plug		
	– No Chainwheel	2	SP3520
	– Chainwheel Port or Starboard side only	1	SP3520
	– Chainwheel Port and Starboard side	0	
18	Plug	2	SP0875
19	Spiral retaining ring		
	– No Chainwheel	0	
	– Chainwheel Port or Starboard side only	1	SP0871
	– Chainwheel Port and Starboard side	2	SP0871
20	Pawl		
	– No Chainwheel	0	
	– Chainwheel Port or Starboard side only	1	2446C
	– Chainwheel Port and Starboard side	2	2446C

21	Spacer – No Chainwheel – Chainwheel Port or Starboard side only – Chainwheel Port and Starboard side	0 1 2	3504 3504
22	Pawl Pin – No Chainwheel – Chainwheel Port or Starboard side only – Chainwheel Port and Starboard side	0 1 2	3435 3435
23	Isolation bush	4	SP0622
24	Rivet	2	SP0529
25	Serial Label	1	3041
26	Bolt – M10 x 80 Lg. Hex. Hd. St St	4	SP0223
27	Washer – Spring M10 StSt304	4	SP0457
29	Bolt - Hex Hd 5/16" UNC x 1-1/2" ss304 – No Chainwheel – Chainwheel Port or Starboard side only – Chainwheel Port and Starboard side	0 2 4	SP0262 SP0262
30	Stripper – No Chainwheel – Chainwheel Port or Starboard side only – Chainwheel Port and Starboard side	0 1 2	3373 3373
31	Chainpipe – No Chainwheel – Chainwheel Port or Starboard side only – Chainwheel Port and Starboard side	0 1 2	2414C 2414C
32	Washer - Flat 5/16" (5/8" OD) StSt304 – No Chainwheel – Chainwheel Port or Starboard side only – Chainwheel Port and Starboard side	0 2 4	SP0413 SP0413
33	Nut - Hex 5/16" UNC StSt304 – No Chainwheel – Chainwheel Port or Starboard side only – Chainwheel Port and Starboard side	0 2 4	SP0321 SP0321
34	Circlip	2	SP0846
35	Key – Single Chainwheel / Single Drum or Double Chainwheel / No Drum – Double Chainwheel / Single Drum – Double Chainwheel / Double Drum	2 3 4	3207 3207 3207
36	Shaft – Single Chainwheel / Single Drum or Double Chainwheel / No Drum – Double Chainwheel / Single Drum – Double Chainwheel / Double Drum	1 1 1	3298 3993 3299
37	Key – Gearbox	1	3150
38	Gearbox	1	P102181
39	Motor – 12V – 24V – Hydraulic	1 1 1	P12073 P12074 P14368
40	Screw –DC Motors - Screw Set Hex Hd M8 x 25 ss304 –Hyd. Motors - Bolt Hex Hd M8 x 35 ss304	2 2	SP0288 SP3216
41	Washer Spring. 5/16" 304ss	2	SP0467
42	Washer Flat 5/16" (5/8" OD) StSt304	2	SP0413
43	O-Ring - 50 id x 2 – DC Motors only	1	SP2787
44	Washer M8 x 24 x 2 – Hydraulic motors only	2	3625
45	Nut Hex 8mm SS304 – Hydraulic motors only	2	SP0366
46	Spacer tube	1	6192
50	Emergency/Clutch Lever – with chainwheel versions only	1	P20043
52	Owners manual	1	P19076

{This page intentionally left blank}

APPENDIX C – Electrical Wiring Schematics

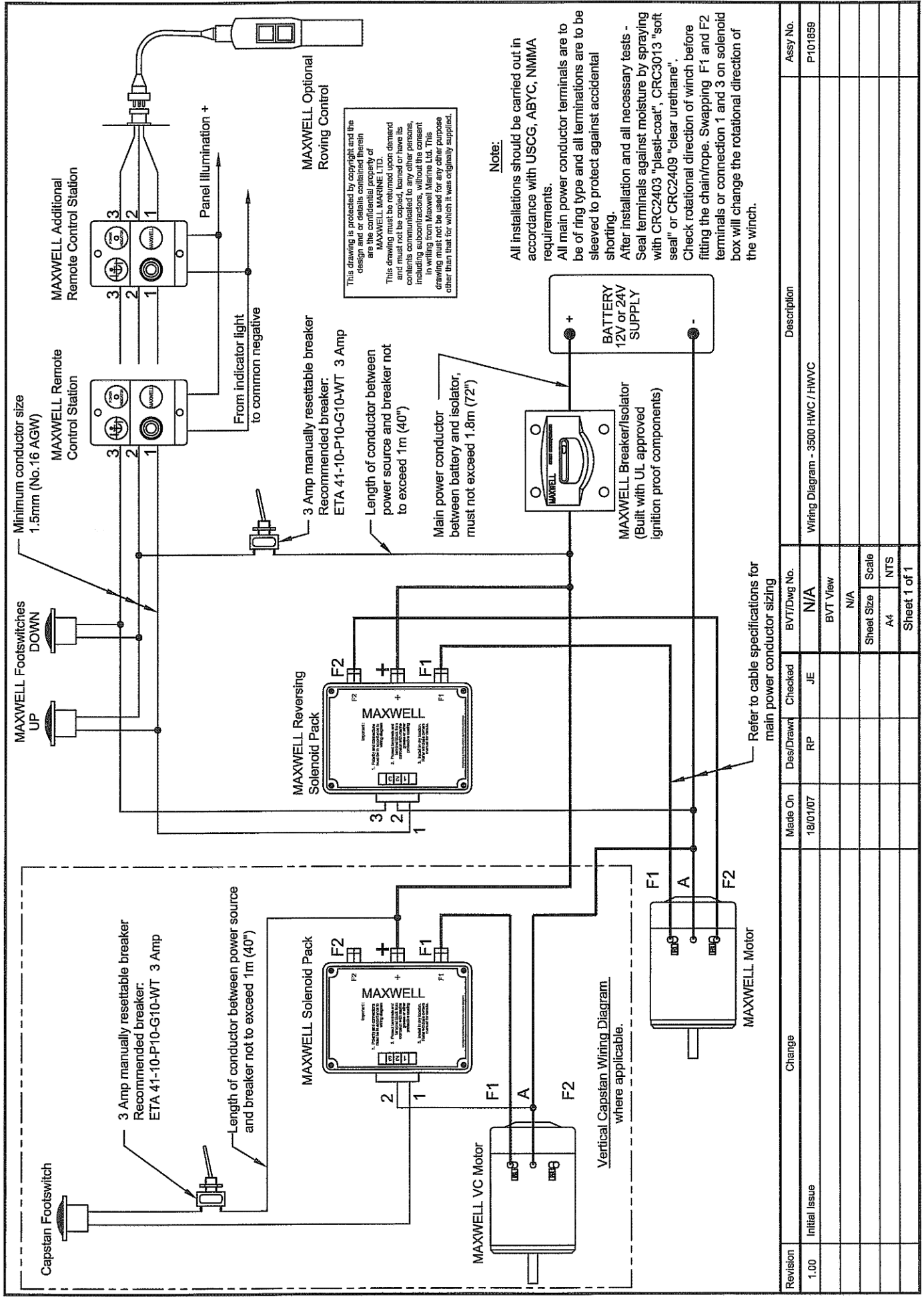

Revision	Change	Made On	Des/Drawn	Checked	BVT/Dwg No.	Description	Assy No.
1.00	Initial Issue	18/01/07	RP	JE	N/A	Wiring Diagram - 3500 HWC / HWVC	P101859
					BVT View		
					N/A		
					Sheet Size	Scale	
					A4	NTS	
					Sheet 1 of 1		

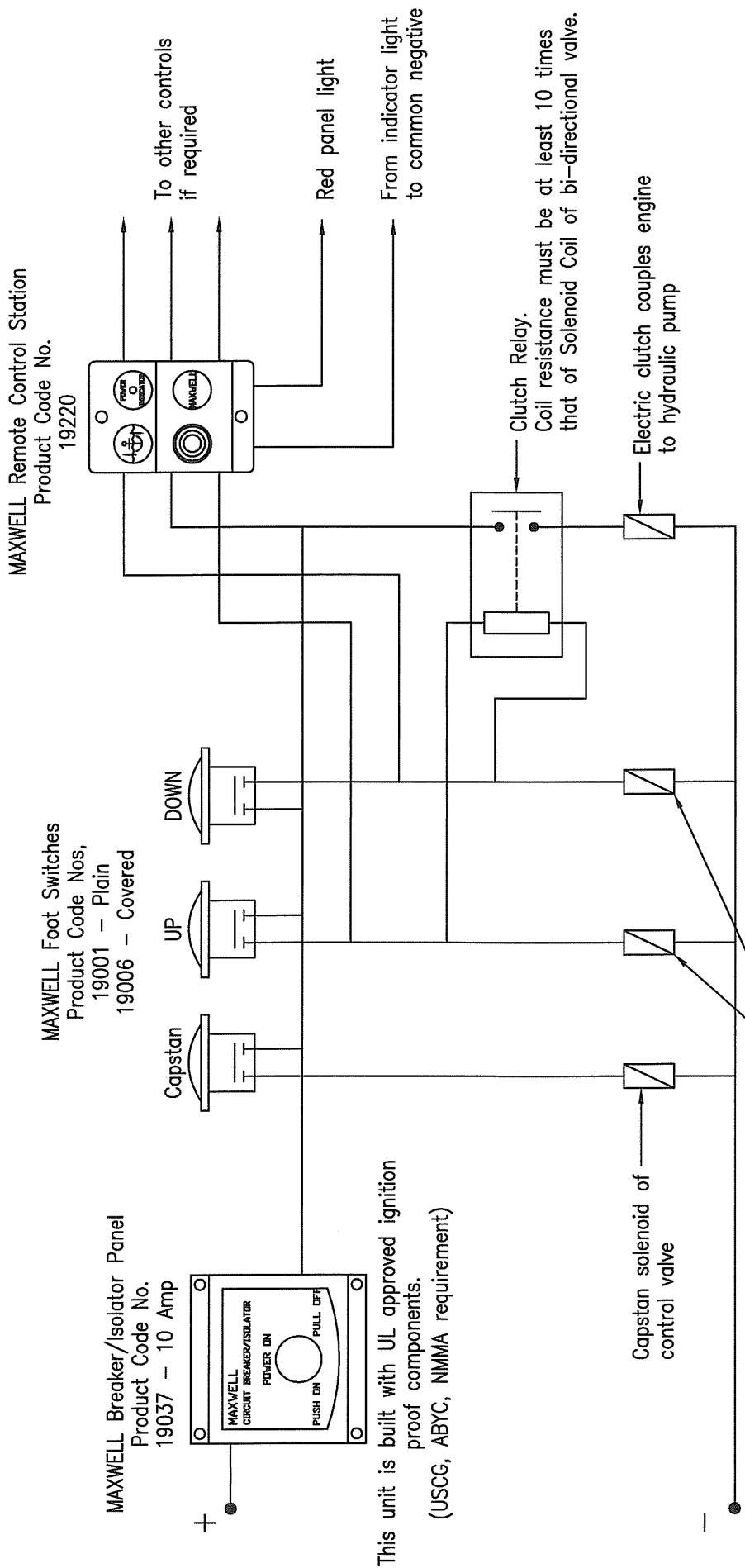

This unit is built with UL approved ignition proof components.
(USCG, ABYC, NMMA requirement)

NOTE:
Min. conductor size 1.5mm (No. 10 AGW)

Sheet Size	Sheet No.	Description	Assembly No.
A4	1 of 1	HWCVC Hydraulic Electrical Control Wiring Diagram.	P101809

BREAKER/ISOLATOR PANEL
— 10A

THIS UNIT IS BUILT WITH UL APPROVED IGNITION
PROOF COMPONENTS (USCG, ABYC, NMMA,
REQUIREMENTS)

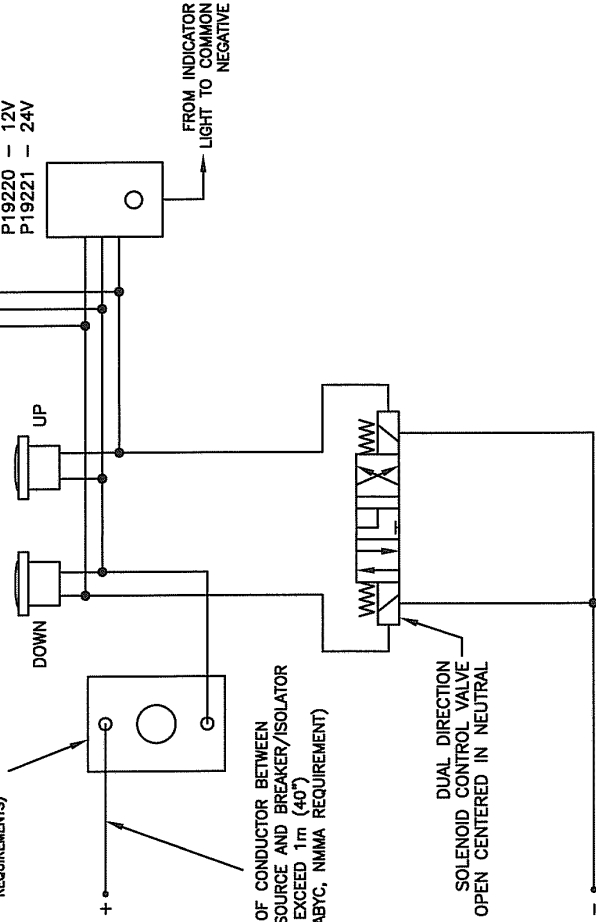

LENGTH OF CONDUCTOR BETWEEN
POWER SOURCE AND BREAKER/ISOLATOR
NOT TO EXCEED 1m (40")
(USCG, ABYC, NMMA REQUIREMENT)

DUAL DIRECTION
SOLENOID CONTROL VALVE
OPEN CENTERED IN NEUTRAL

ALL INSTALLATIONS SHOULD BE CARRIED OUT IN
ACCORDANCE WITH USCG, ABYC, NMMA, OR
CLASSIFICATION SOCIETY REQUIREMENTS.

MINIMUM CONDUCTOR SIZE 1.5mm² (AWG 16)
(USCG, ABYC, NMMA REQUIREMENT)

Rev.	Description	Date	Name	Checked
3.00	Removed clutch relay	29/04/03	DRW	
4.00	Control Station Codes corrected	07/06/07	RP	JE

**ELECTRIC CONTROL WIRING DIAGRAM FOR
HYDRAULIC WINDLASSES**

MAXWELL WINCHES LTD.
AUCKLAND NEW ZEALAND

P101821

Windlass		Recommended flow		Relief valve pressure setting	
Series	Motor	l/min	US gal/min	PSI	bar
3500	P14368 GRESEN MGG2-25	40	11	2000	138

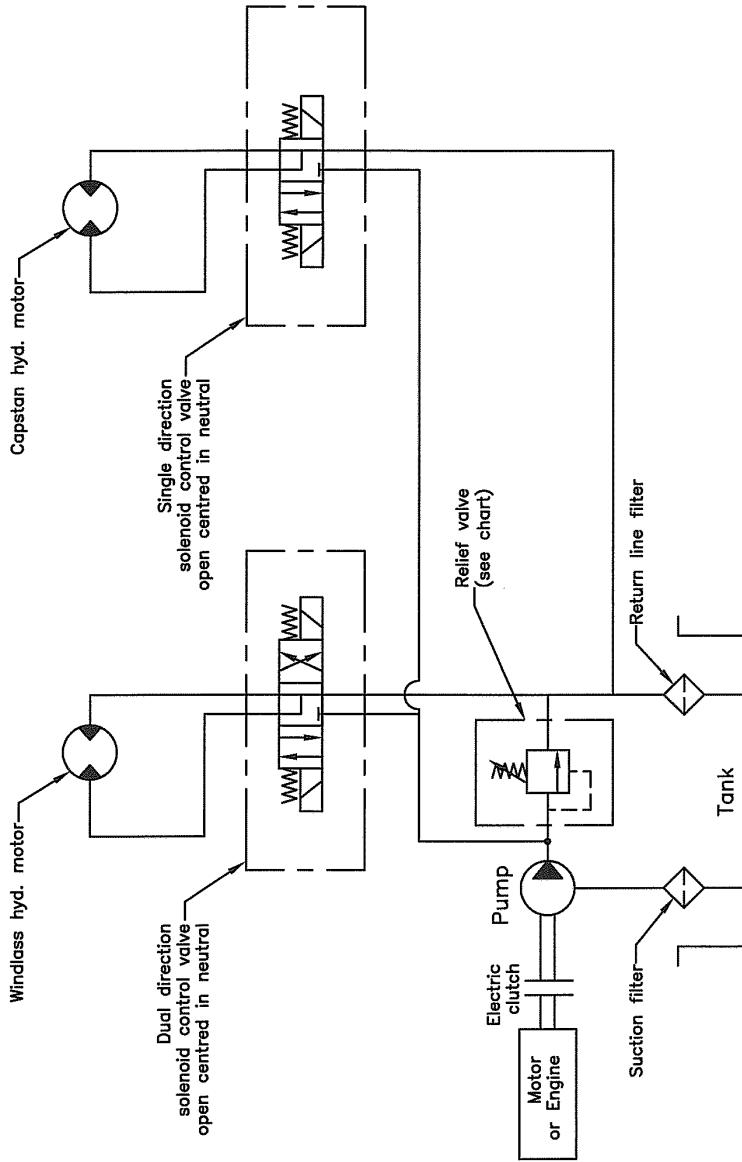
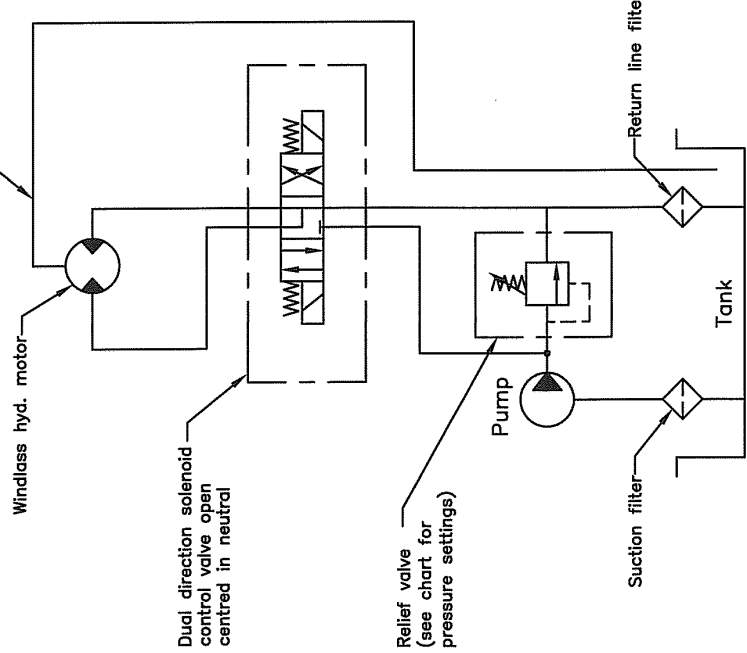

Chart refers to MAXWELL "standard build". Lower flow and pressure can be accommodated – refer to manual or consult MAXWELL. Ensure that selected hydraulic components are adequate for recommended flow rate.

Revision	Description	Date	Name
1.00	INITIAL ISSUE	31/10/05	JE
HYDRAULIC SCHEMATIC WINDLASSES HWVC 3500			
MAXWELL WINCHES LTD. AUCKLAND NEW ZEALAND			
P101848			

Case drain
(Galtech motor-SP2250 only)



Series	Windlass		Recommended flow		Relief valve pressure setting	
	Motor	Motor	l/min	US gal/min	PSI	bar
1000	P14366	GRESEN MGG2-16	20	5.3	1450	100
1500	P14366	GRESEN MGG2-16	20	5.3	2000	138
2200	P14369	GRESEN MGG2-30	36	9.5	1800	124
2500	P14368	GRESEN MGG2-25	32	8.5	2000	138
Liberty	P14368	GRESEN MGG2-25	27	7.3	1200	83
3500	P14368	GRESEN MGG2-25	32	8.5	1700	117
4000	SP2250	GALTECH 2SM-A-19	50	13.2	1500	103

Chart refers to MAXWELL "standard build". Lower flow and pressure can be accommodated - refer to manual or consult MAXWELL.

Ensure that selected hydraulic components are adequate for recommended flow rate.

Case drain can only connect to return line if return line pressure always remains below 25 PSI. Otherwise case drain must connect to tank

Revision	Description	Date	Name	Checked
7.00	Removed pressure switch, Added liberty	29/04/03	DRW	
8.00	Corrected Liberty and 4000 flow & pressure setting figures. Corrected case drain flow detail	08/09/06	RP	DH
9.00	SP2250 Galtech motor was SP2224 Eaton	06/06/07	RP	JE

<p>HYDRAULIC SCHEMATIC WINDLASSES 1000 - 4000</p>	<p>MAXWELL WINCHES LTD. AUCKLAND NEW ZEALAND</p>
<p>P203103</p>	

LIMITED WARRANTY

Warranty: Vetus-Maxwell APAC Ltd provides a three year limited warranty on windlasses for pleasure boat usage, and a one year limited warranty for those systems used on commercial or charter vessels. Warranty, service and parts are available around the world. Contact your nearest Vetus-Maxwell office for a complete list of service centres and distributors.

This warranty is subject to the following conditions and limitations:

1. This Warranty will be null and void if
 - (a) there is any neglect or failure to properly maintain and service the products.
 - (b) the products are serviced, repaired or maintained improperly or by unauthorised persons.
 - (c) loss or damage is attributed to any act, matter or omission beyond the reasonable control of Vetus-Maxwell or the purchaser.
2. Vetus-Maxwell APAC Ltd liability shall be limited to repair or replacement (as determined by Vetus-Maxwell) of the goods or parts defective in materials or workmanship.
3. Determination of the suitability of the product and the materials for the use contemplated by the buyer is the sole responsibility of the buyer, and Vetus-Maxwell shall have no responsibility in connection with such suitability.
4. Vetus-Maxwell shall not be liable for any loss, damages, harm or claim attributed to:
 - (a) use of the products in applications for which the products are not intended.
 - (b) corrosion, wear and tear or improper installation.
 - (c) improper use of the product.
5. This Warranty applies to the original purchaser of the products only. The benefits of the Warranty are not transferable to subsequent purchasers.
6. Vetus-Maxwell shall not be responsible for shipping charges or installation labour associated with any warranty claims.
7. There are no warranties of merchantability, fitness for purpose, or any other kind, express or implied, and none shall be implied by law. If any such warranties are nonetheless implied by law for the benefit of the customer they shall be limited to a period of three years from the original purchase by the user.
8. Vetus-Maxwell shall not be liable for consequential damages to any vessel, equipment, or other property or persons due to use or installation of Vetus-Maxwell equipment.
9. This Warranty sets out your specific legal rights allowed by Vetus-Maxwell APAC Ltd ; these may be varied by the laws of different countries. In addition, the purchaser may also have other legal rights which vary from country to country.
10. To make a claim under this Warranty, contact your nearest Vetus-Maxwell or distributor. Proof of purchase and authorisation from Vetus-Maxwell will be required prior to any repairs being attempted.



To be eligible for warranty protection, please either complete the form below at the time of purchase and return it to the appropriate retailer or supplier of the goods, or fill out the electronic Warranty Form on our website, www.maxwellmarine.com

Purchaser

Name:	
Telephone:	Facsimile

Address:

Supplier / Dealer

Name:	
Telephone:	Facsimile

Address:

Windlass Model

Serial Number

Date of Purchase	Boat Type	Windlasses Supplied <input type="checkbox"/> With boat <input type="checkbox"/> Fitted by boat yard/dealer <input type="checkbox"/> Purchased from dealer/chandler
Name		
Built by		
L.O.A.		



